

EELA AUDIO SYSTEM S 100

S 100

is standard equipped
with 83 mm conductive
plastic penny & giles faders

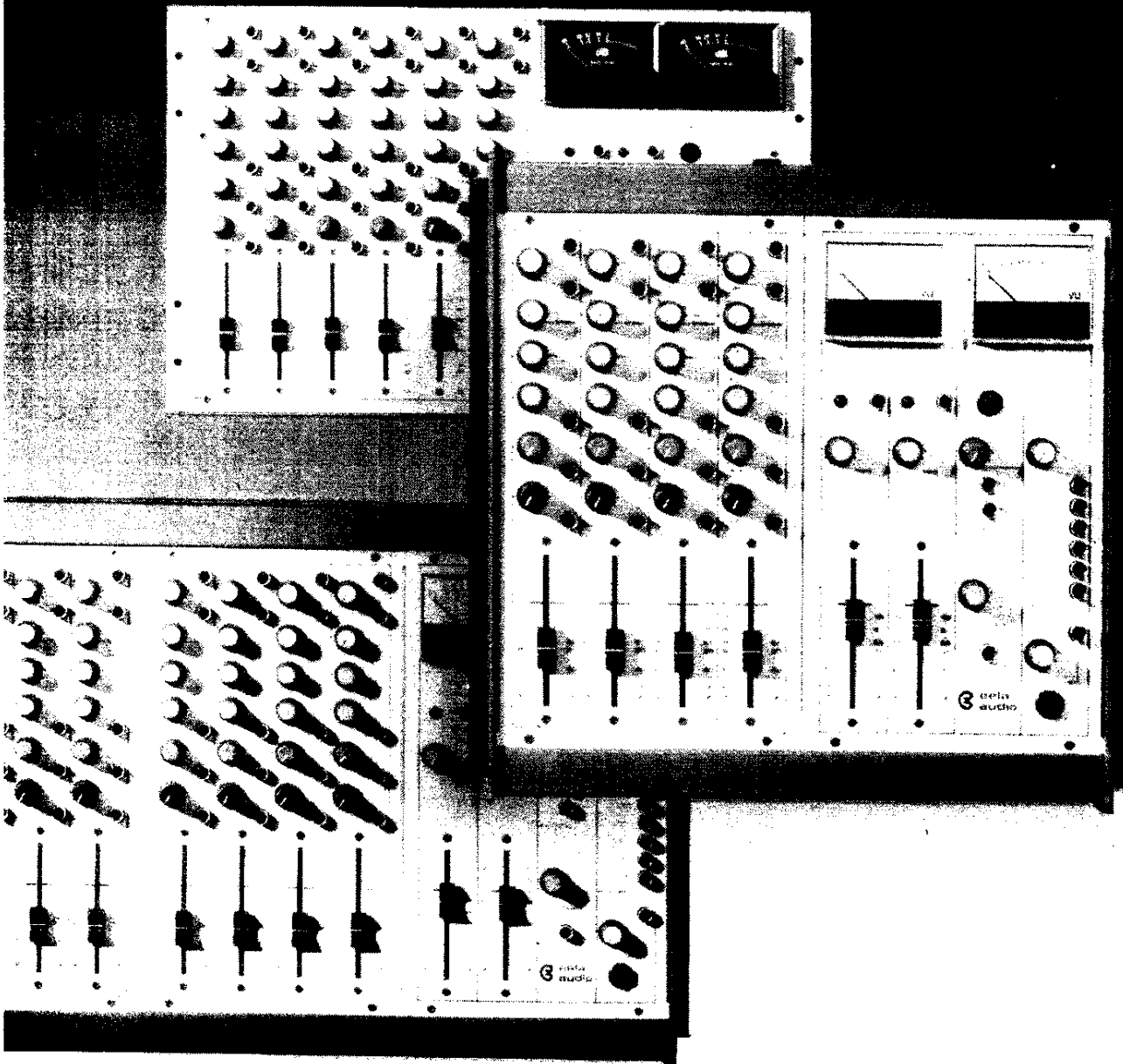

eela
audio

The EELA AUDIO S 100

Consists of a module system, the versatility of which lends itself to the assembly of mixers of multiple configurations, using a method of construction that makes for a simple, sturdy and attractive unit.

These mixers have been designed specifically for those people who need a simple, but high quality professional mixer for use in:

mono, stereo and four track studio's, broadcast stations, audio-visual units, film- and video dubbing studio's, hospital broadcast, theaters and other public address systems.

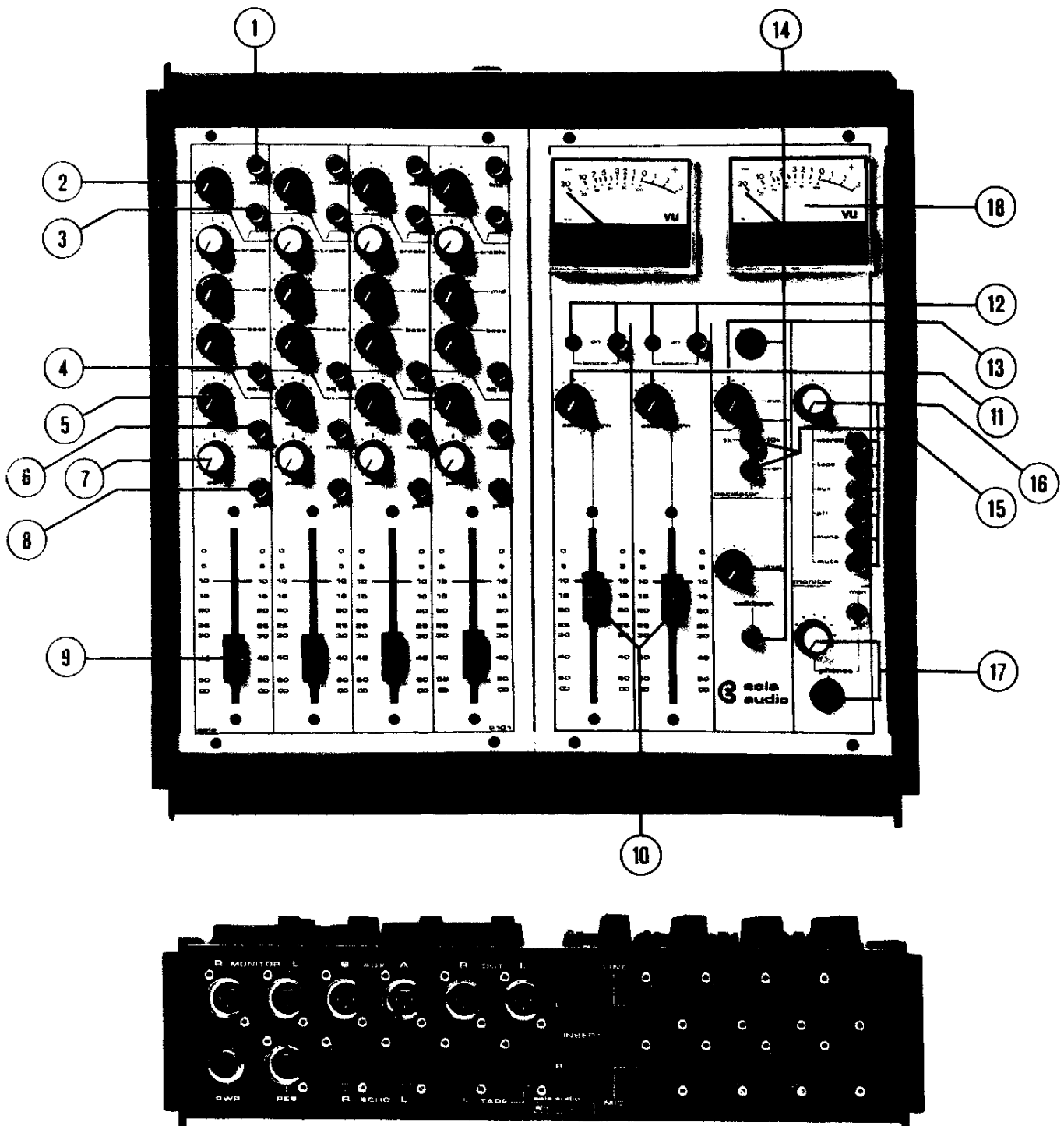

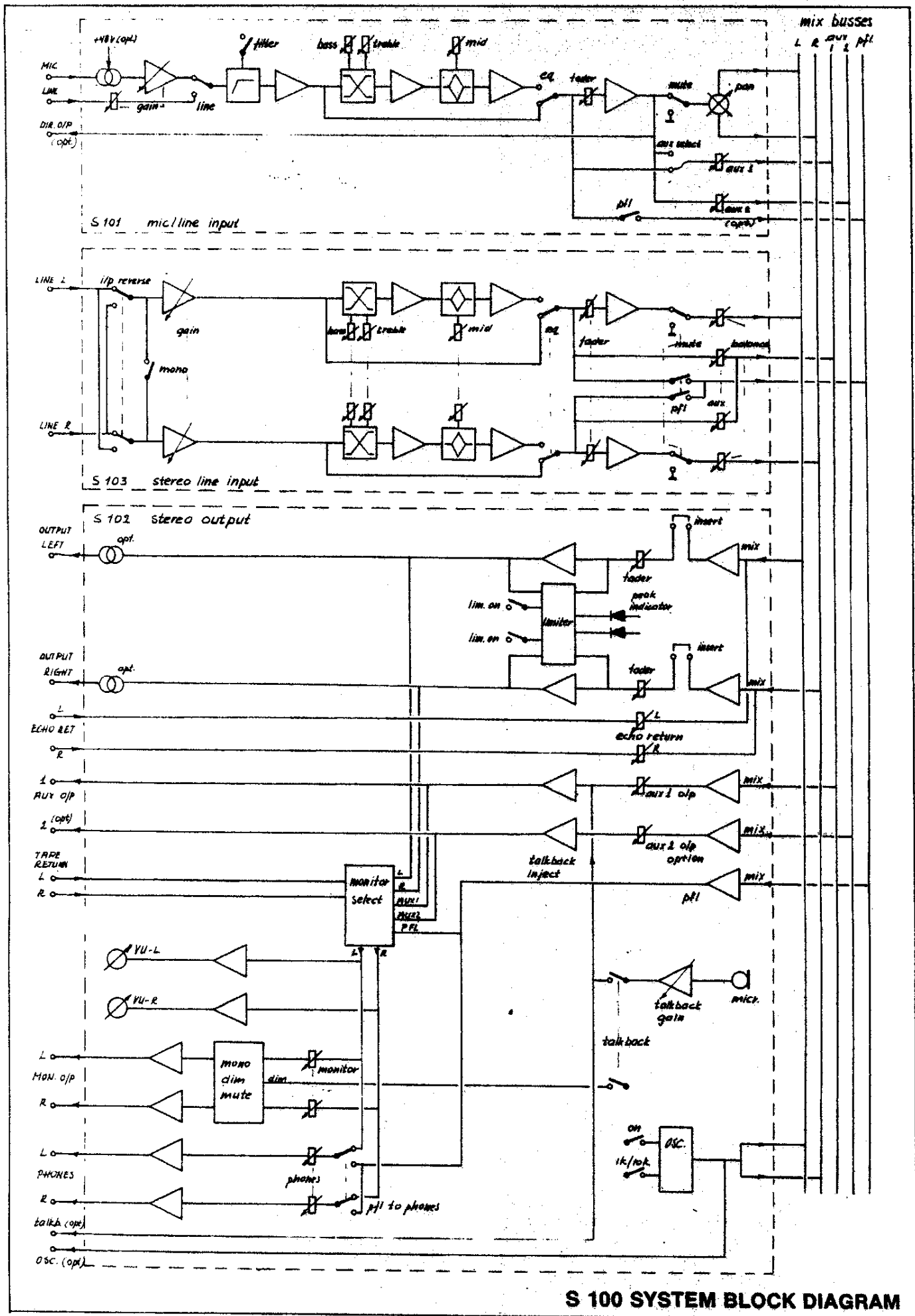

S 100 SYSTEM BLOCK DIAGRAM

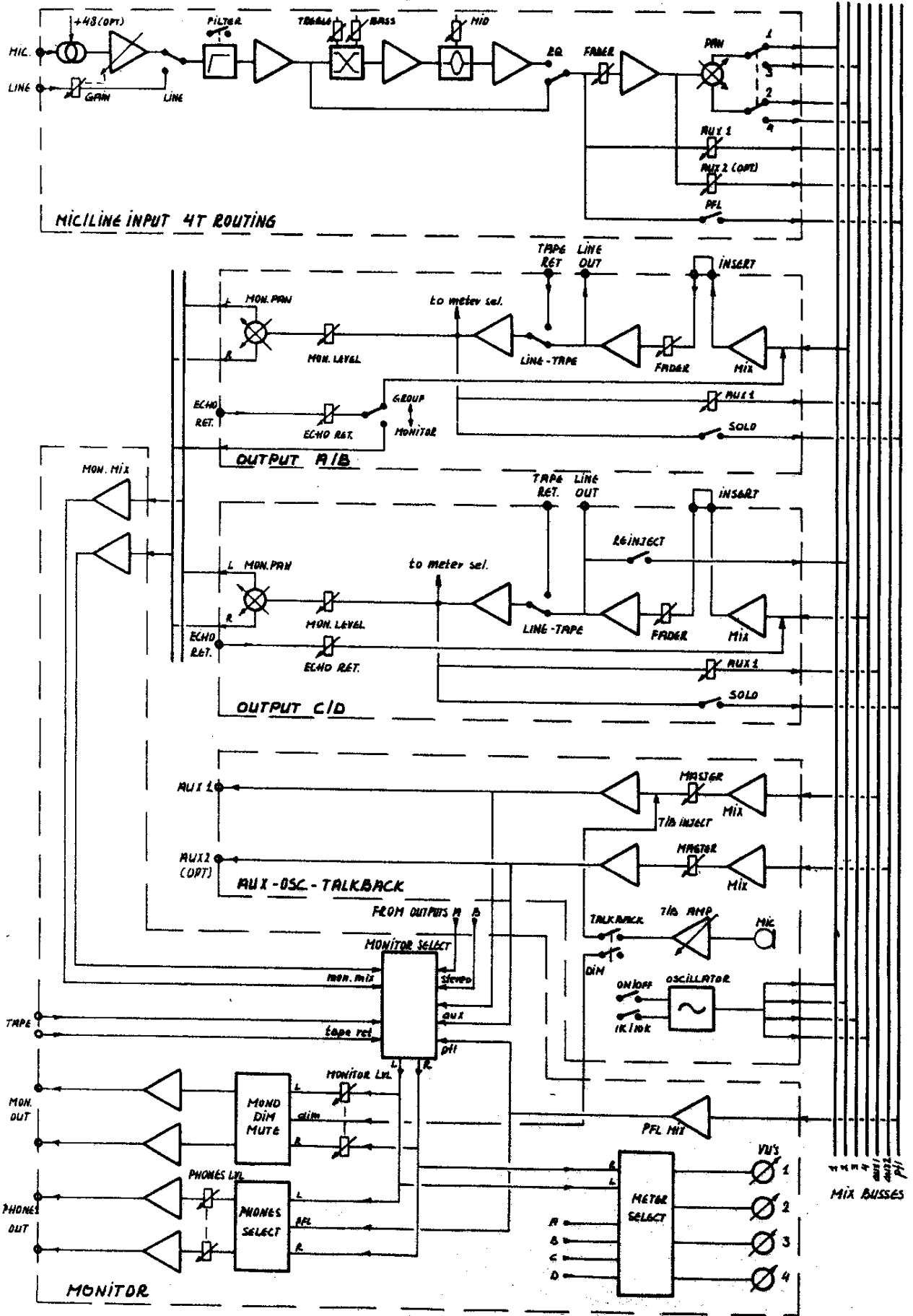

EELA AUDIO S100 SERIES BLOCK DIAGRAM 4 GROUP VERSION

MODULE DESCRIPTIONS

S 101

input block with 4 mic/line inputs

1. two separate INPUTS for microphone and line per channel on XLR connectors, switch selected. The MIC input is transformer-balanced and, as an option, can be wired for 48 Volt phantom power. The LINE input is standard unbalanced, but a transformer balanced version is optional available.
2. GAINCONTROL for both mic and line with a sufficient range, 40 dB for mic, 20 dB for the line input. A dual concentric pot with separate controls for mic and line gain is optional available.
3. A switchable HIGH PASS FILTER, to eliminate any extraneous low frequency interference. Effective on both mic and line inputs.
4. A three band equaliser with its on/off switch. This switch is particularly useful in permitting a quick comparison between an equalised and linear signal.
5. An AUX SEND per channel, that can be wired pre- or post-fader.
A second send can be fitted, using dual-concentric controls. A maximum of two clean feed busses are available for extra post-fader outputs.
This allows for connection of telephone hybrids etc.
6. A MUTE switch to kill the stereo output without affecting direct outputs, PFL or auxiliary sends.
7. A PANORAMA potentiometer of the conventional constant power law type.
For special applications this can be replaced by a 3-position switch for routing to left, left + right or right outputs.
8. A PRE-FADER-LISTEN or PFL switch routes the prefader signal to the monitors and meters. More than one PFL switch can be depressed at a time to enable a number of signals to be monitored simultaneously.
9. The FADER has a stroke length of 70 mm. The standard unit fitted is a PREH type, the best in the carbon track range.
For more exacting requirements a DUNCAN conductive plastic track fader can be supplied.
A microswitch at the end of the track can be fitted to enable remote start of turntables, tape machines or for red light signalling.

S 104

input block with 4 mic/line inputs 4 group routing.

Identical to the S 101 module with unbalanced line inputs with the exception of the MUTE switch, which is replaced by a A-B/C-D group routing.

S 103

input block with 4 stereo line inputs.

- Two unbalanced line inputs per channel allowing for connection and control of stereo sources with a single set of controls.
- GAIN-control with 20 dB range.
- Switch for LEFT-RIGHT REVERSE.
- MONO/STEREO SWITCH to be able to use a mono signal on one input to be fed to two outputs or a stereo signal to give a monaural output.
- EQUALISER, three band, identical to the one used in the S 101 inputs with ganged controls for left and right.
With EQ on/off switch.
- One mono AUX SEND, derived from both inputs. Can be selected pre- or post fader by a wire-link on the PC-board.
- MUTE switch for the main outputs.

- BALANCE control with +/- 10 dB range for correcting the stereo image.
- A stereo linear FADER with optional available a switch for remote start etc.
- A PFL switch with mono output from both inputs.

S 102

stereo output block

Main outputs left and right

10. Two mix- and output amps for left and right controlled by linear FADERS.
The output stages are low impedance with high current drive capability. Provisions have been made to fit output transformers to give galvanic isolation when required.
An insertion point pre-fader allows external equipment to be inserted into the stereo mix.
11. Two ECHO-RETURNS, direct to the outputs on rotary controls.
12. A broadcast quality LIMITER can be switched into each output channel, to prevent overload in connected equipment. The threshold is fixed at the peak output level. Attack- and release time constants have been selected for minimal audible distortion of the signal. An optional stereo-link between the two limiters can be made.
Limiting is indicated by LED's.
When the limiters are not in use the gain-reduction LED's act as PEAK-LEVEL INDICATORS.

Auxiliary circuits

13. Mix- and output amps for aux-send(s) with rotary MASTER-control(s).
14. A frontpanel mounted electret condenser microphone for TALKBACK with gaincontrol and push-to-talk button.
The output signal of this circuit is normally sent to the aux. 1 output.
Actuating the switch dims the controlroom monitor output to prevent howl-round.
A separate talkback output is optional available.
15. A LINE-UP OSCILLATOR is available in this section, with a choice of two frequencies, 1 kHz and 10 kHz. Its output is fed to the main outputs to facilitate the alignment of external equipment; even a complete record line-up of tape machines is possible without using external measuring gear.

Monitor circuits

16. A bank of pushbuttons switch the following sources to the monitor outputs and meters:
 - main stereo outputs
 - stereo tape return
 - aux output
 - the output of the PFL mix-ampA pushbutton labeled MONO mixes both signals to check phase and mono/stereo compatibility.
A MUTE switch switches off the loudspeaker outputs.
17. A HEADPHONE output mounted on the frontpanel can be switched to receive the monitor signal or the PFL-mix. It has a separate level-control and has been designed for high impedance headphones like AKG, BEYER or SENNHEISER. This output is not affected by the dim- or mute circuits.

Meters

18. Standard meters are SIFAM AL 22 VU's.
As an option TOYO ppm's with a range of -40 to +5 dB can be fitted or BS ppm's with 1 to 7 scale.
The meters follow the monitor selector switch bank.

TECHNICAL SPECIFICATIONS EELA AUDIO S 100 SERIES MIXING CONSOLES

Measurements done on a 8 into 2 standard mixer, equipped with Duncan faders.

LEVELS

| | |
|--------------------------------|-----------------------------------|
| Sensitivity of mic. input | : max. - 80 dBv |
| Gain control | : 40 dB |
| Sensitivity of line input | : max. - 24 dBv |
| Gain control | : 20 dB |
| Level at insert points | : - 2 dBv |
| Line output levels | : + 4 dBv, +6 dBv to be specified |
| Maximum output on 600 Ohm load | : + 21 dBv |

IMPEDANCES

| | |
|-------------------------------|---|
| Input impedance of mic. input | : \geq 1200 Ohm |
| Input impedance of line input | : unbalanced 10 kOhm balanced 8 kOhm |
| Source impedance outputs | : unbalanced \leq 20 kOhm balanced \leq 75 Ohm |

FREQUENCY RESPONSE

| | |
|---------------------------|--|
| No EQ. filters off. | |
| all inputs to all outputs | : 20 Hz - 20 kHz (0, -1 dB) |
| High pass filter | : 12 dB/oct., - 3 dB point at 70 Hz |
| Treble control | : + - 16 dB at 10 kHz, shelving |
| Mid control | : + - 10 dB at 3 kHz bell curve, Q = 1.4 |
| Bass control | : + - 16 dB at 50 Hz shelving |

OVERLOAD MARGIN

| | |
|--|----------------|
| Max. level at mic. input, | |
| THD \approx 1% at 40 Hz | : - 2 dBv |
| Max. level at line input, | |
| THD \approx 1% at 40 Hz | : + 20 dBv |
| Overload margin at channel-of-groupfader | : \geq 22 dB |

NOISE

Noise voltages are measured with a mean value reading voltmeter, calibrated in V_{eff} , using a bandpass filter 30 Hz - 18 kHz with 6 dB oct. slopes, unweighted.

| | |
|--------------------------------|-------------------|
| Eff. noise at mic input, | |
| source impedance 200 Ohm | : \leq -124 dBv |
| Signal noise ratio, | |
| limiter in output fader closed | : 86 dB |
| one channel unity gain with EQ | : 83 dB |
| 8 channels unity gain with EQ | : 80 dB |

DISTORTION

From mic or line input to all outputs at operating level, no limiter

| | |
|----------------------------------|-------------------------|
| THD at 30 Hz | : 0.07% |
| 1 kHz | : 0.03% |
| 10 kHz | : 0.03% |
| 20 kHz | : 0.06% |
| Limiter on, 10 dB limiting 1 kHz | : \leq 0.2% |
| Slew rate | : \geq 8 V/ μ sec |

CROSSTALK

| | |
|--|-----------------------------|
| Faderdamping at 10 kHz | : 86 dB |
| Mute-damping at 10 kHz | : 96 dB |
| Panpot-damping at 10 kHz | : 68 dB |
| Mic/line crosstalk at 10 kHz | : 75 dB |
| Mic input loaded with 200 Ohm, max gain, line input level nominal. | |
| Left/right crosstalk stereo line input | : 56 dB at 10 kHz |
| Common mode rejection of mic. input | : \geq 80 dB up to 10 kHz |

LIMITER

| | |
|----------------------------|---|
| Threshold | : + 6 dBv/+10 dBv according to customer specification |
| Attack time | : 1 msec. |
| Release time | : 0.5 sec. |
| Max. gainreduction | : \geq 20 dB |
| Stereo-coupling (optional) | : better than 2 dB |

POWER SUPPLY

| | |
|---|--|
| External mains powered | |
| Input | : 100/200 Volt or 200/240 Volt 50/60 Hz |
| Output | : +18V 0.7 A -18V 0.7 A +48V 0.05 A for phantom power (optional) |
| Power consumption of typical 8 into 2 console | : 300 mA |

DIMENSIONS

| | |
|---------------------|----------------------|
| CH 2 chassis (4/2) | : 390 x 390 x 100 mm |
| CH 3 chassis (8/2) | : 570 x 390 x 100 mm |
| CH 4 chassis (12/2) | : 750 x 390 x 100 mm |
| CH 5 chassis (16/2) | : 930 x 390 x 100 mm |

eela
audio
eindhoven-holland

hondsruglaan 83a
5628 DB eindhoven
tel: 040-424455
tlix: 59281 bolle nl,

Dealer:

S 191

19" rackmount version of S 100 mixer

Available in a 6 into 2 configuration with 6 mic/line inputs. Designed for use in studio's based on 19" units as are many video- and film workshops.

Frontpanel dimensions are 19" by 7 U (12.25"). Maximum depth is 130 mm.

Almost all the benefits, special features and options of the standard S 100 range are available like:

PPM's
bal. outputs
2e aux send
fader switches
etc.

Connections are by means of XLR connectors, mounted underneath the special shaped housing of the S 191. By this shape no extra rackspace for connections will be occupied and when mounting the unit in a table top no extra depth is added.

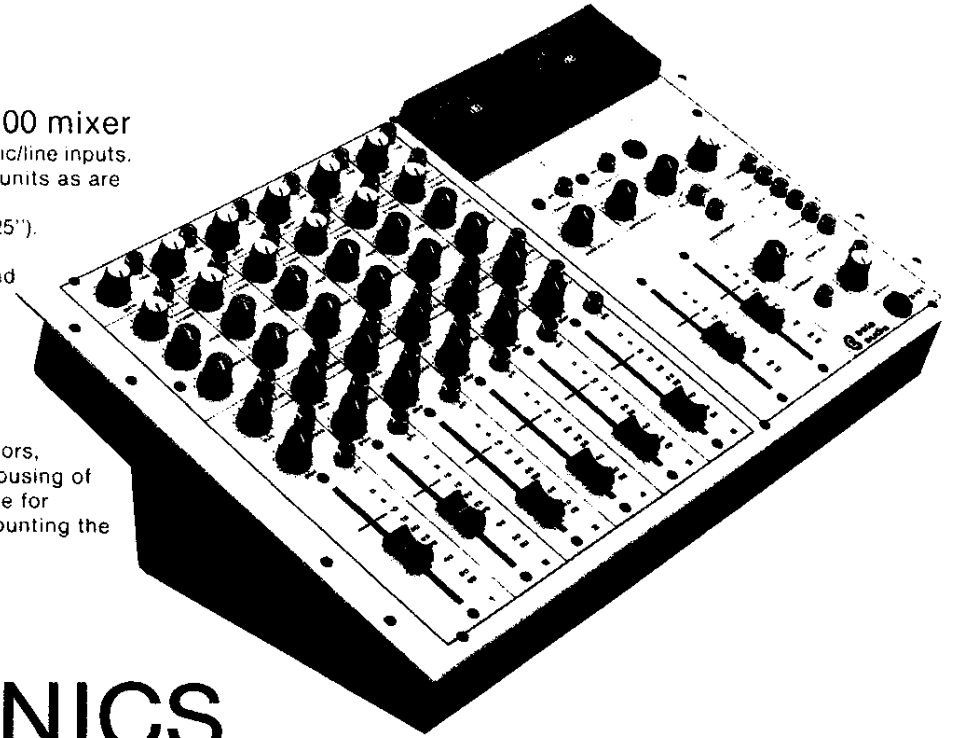

ELECTRONICS

By using a minimum of hard wiring and a rational approach to design any repairs and modifications are made very simple.

The circuit boards are equipped with solder masks and silkscreened with component positions.

The boards are fixed to the frontpanels by means of the potentiometer nuts and are only connected together with a pluggable flat cable.

Each board can be removed separately.

The switches are of the self-indicating "fish-eye"-type, giving a clear visual indication of their position.

Electronic components used are top-quality, the amplifiers are the most sophisticated opamps available today.

A great deal of time has been spent in research and development to achieve a design which uses the latest technology, to obtain a very low noise, wide bandwidth and low distortion mixer with the flexibility necessary to suit the varying requirements of the sound industry.

But last and not least to provide the sound engineer with an extremely reliable and workable tool for years of troublefree operation.

Possible chassis sizes.

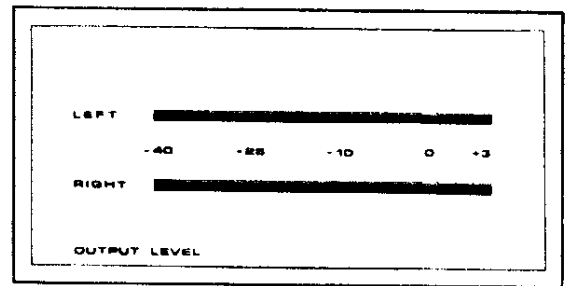
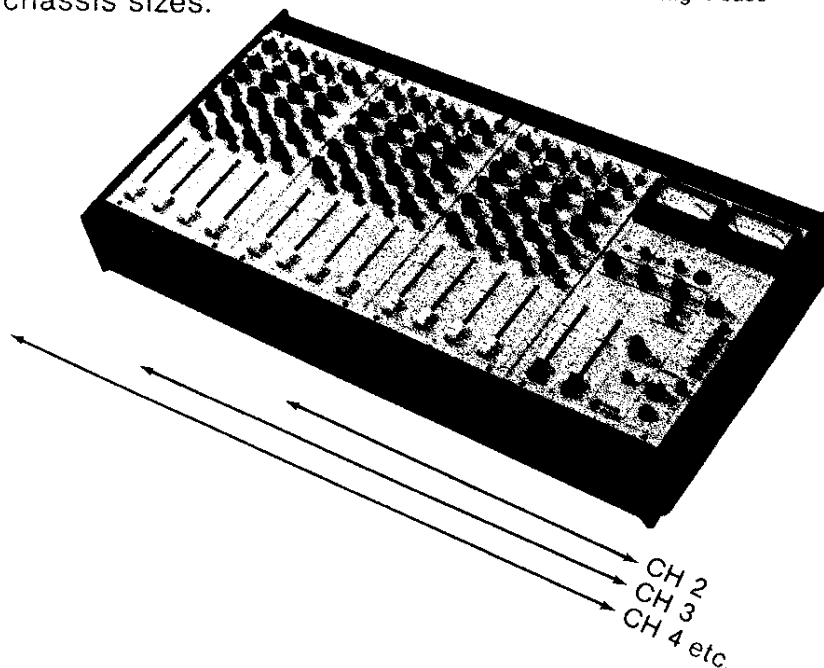

Options

- Dual LED peakmeter
- British Standard PPM's
- transformerbalanced outputs
- extra sends or mixing busses for clean feeds
- fader-activated switches
- multiway connectors
- extra meterpanel
- small loudspeaker and amplifier
- extended armrest
- flight case

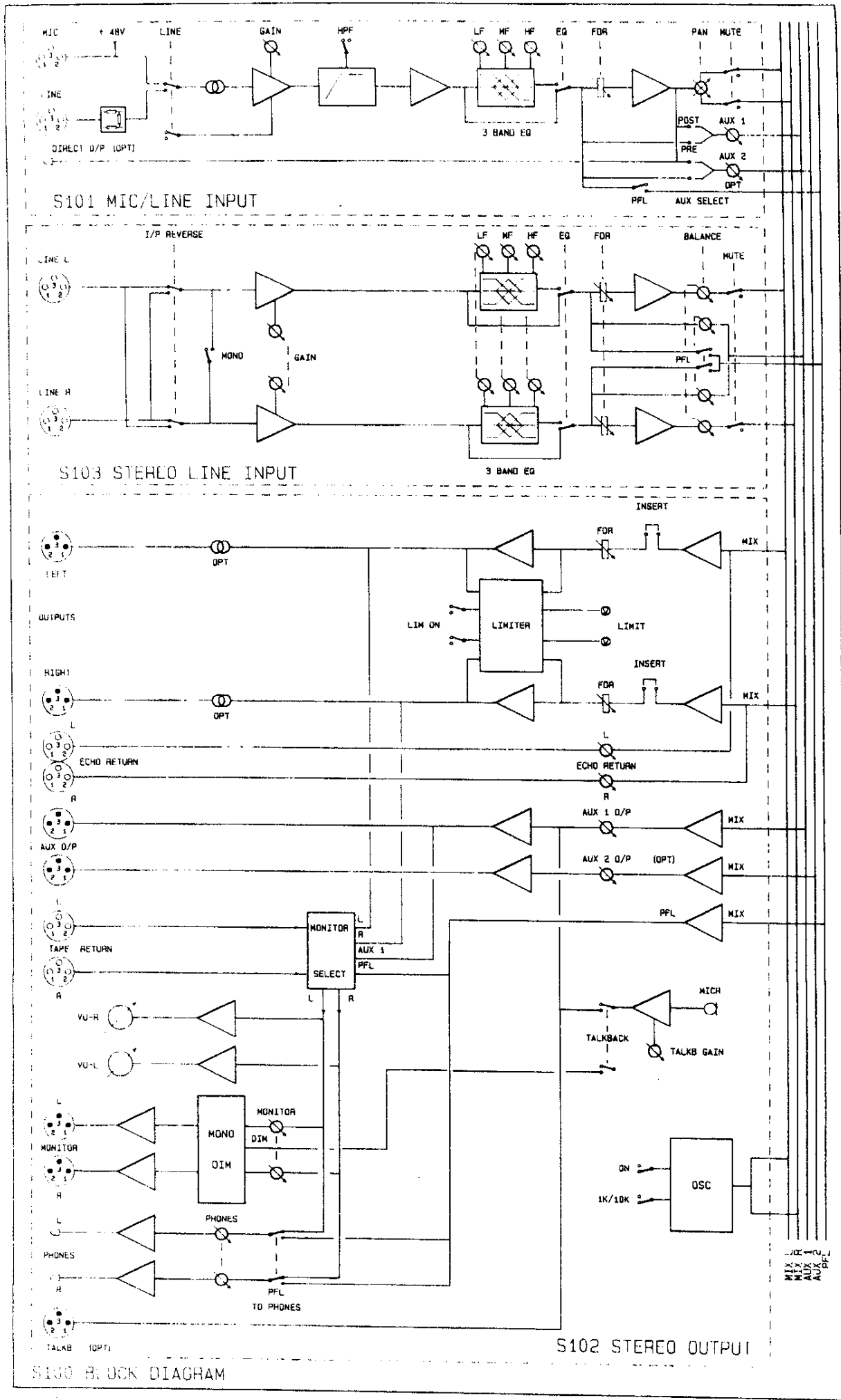

S100 BLOCK DIAGRAM

S102 STEREO OUTPUT

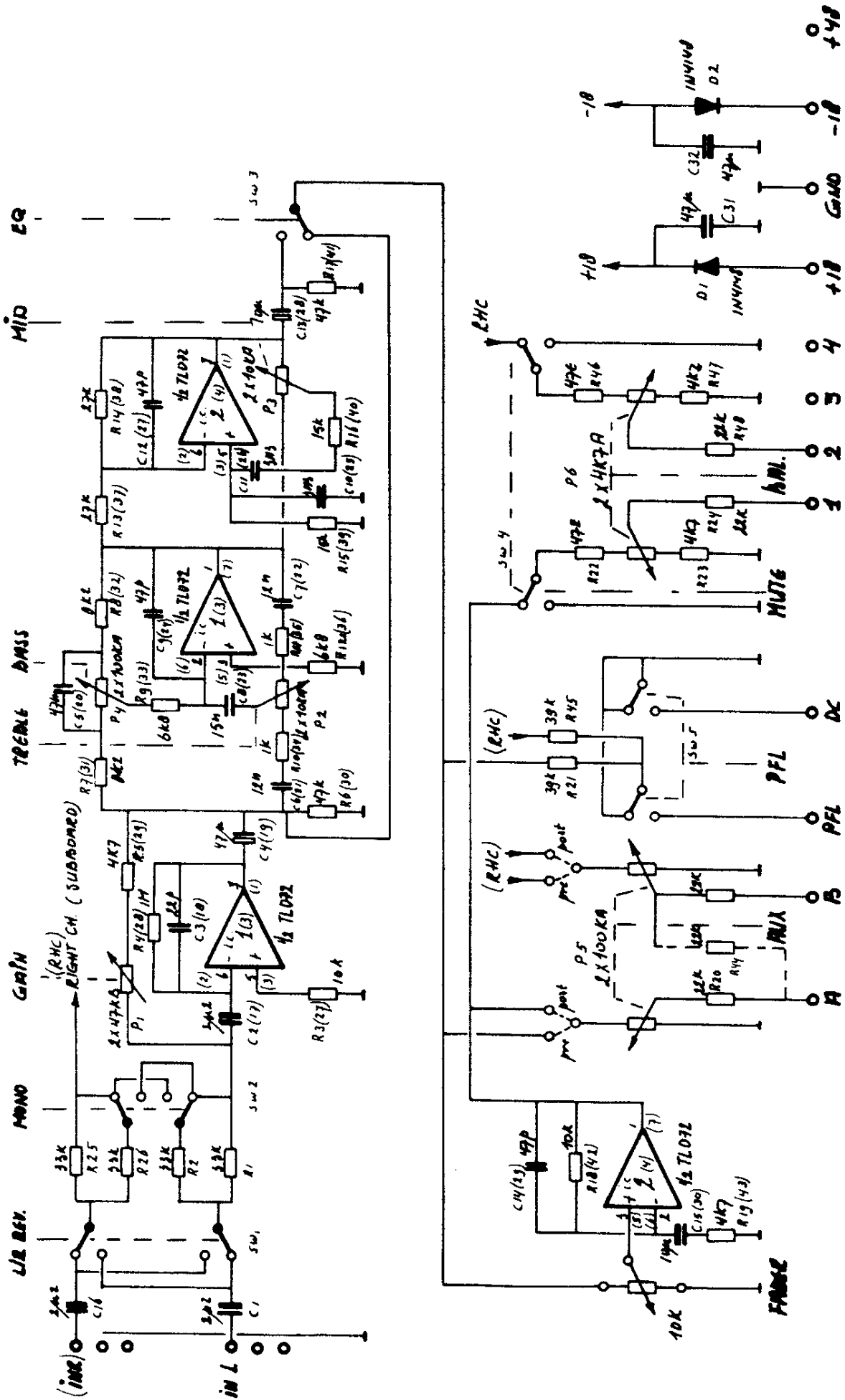

ECLA AUDIO 05-10-80 FVE STEREO LINE INPUT S100 (UNBAL / WITH EQ)

8/4

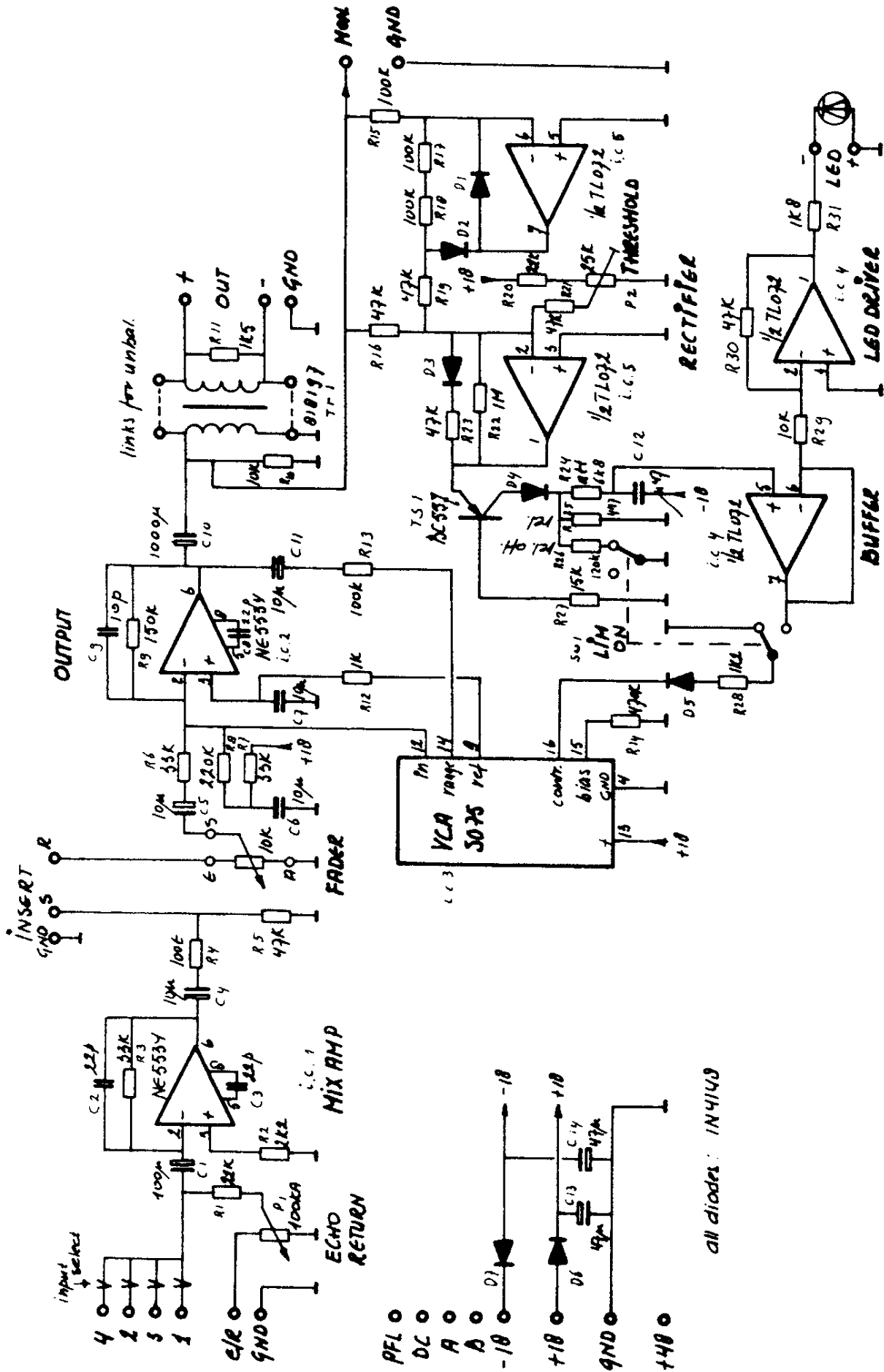

all diodes: 1N4148

GEELR AUDIO 19-06-81 FVE OUTPUT S100 STEREO INCL. LIMITER 815.3

AUX OUTPUTS

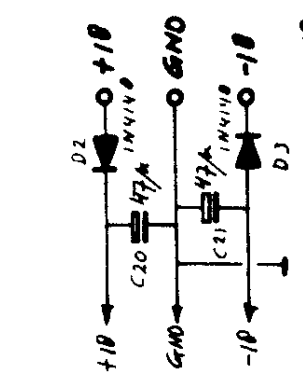

TL072's can be replaced by NE552's

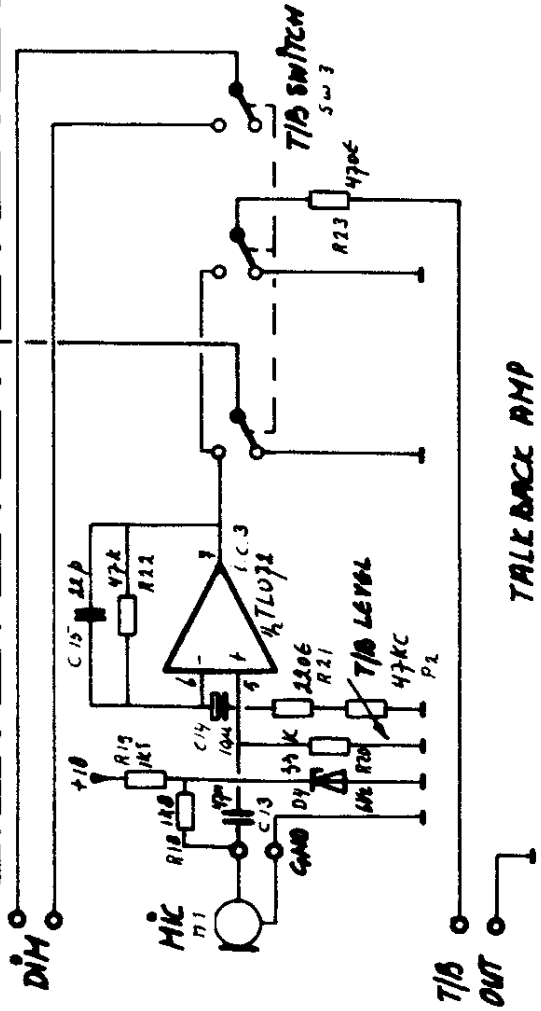
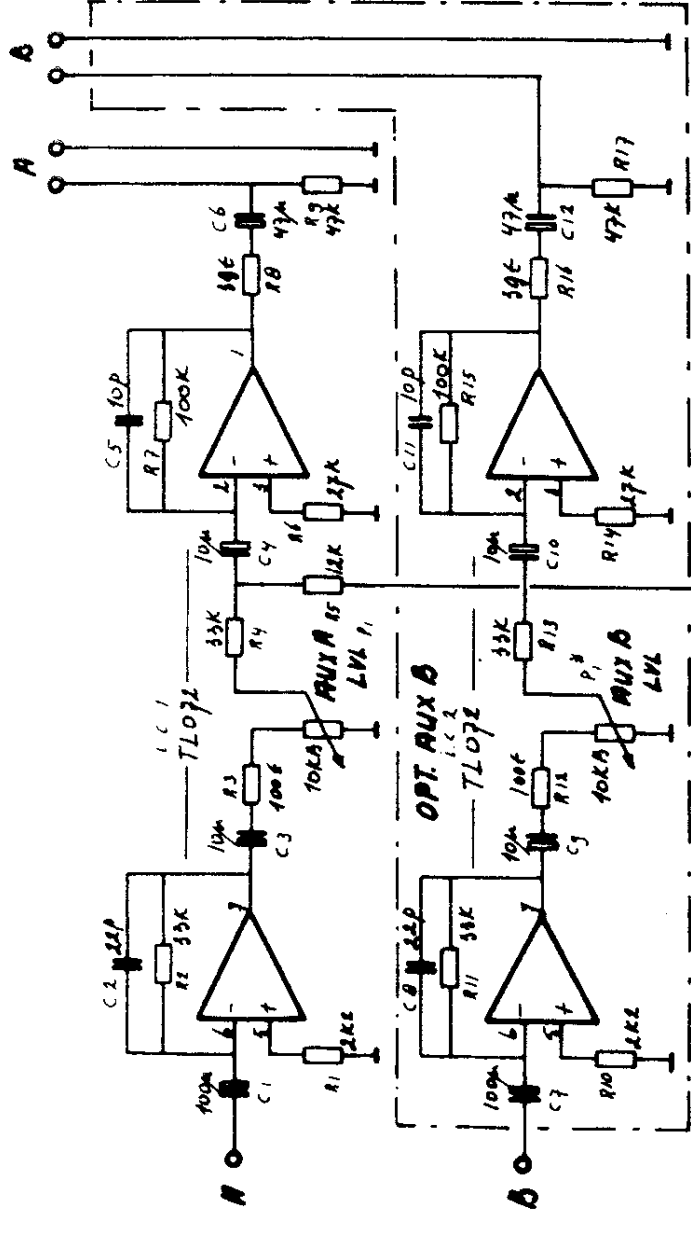

TALK BACK AMP

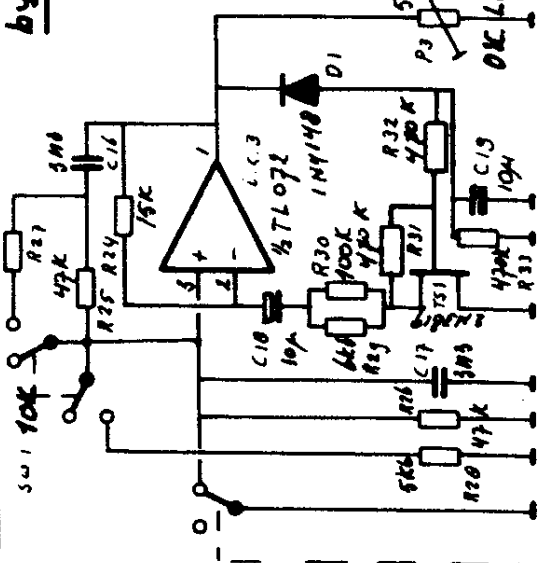

OSCILLATOR

SW 2 OSC ON

816.2

AUX-OSC-T1B MODULE S100

EELA AUDIO 16-06-81 FVE

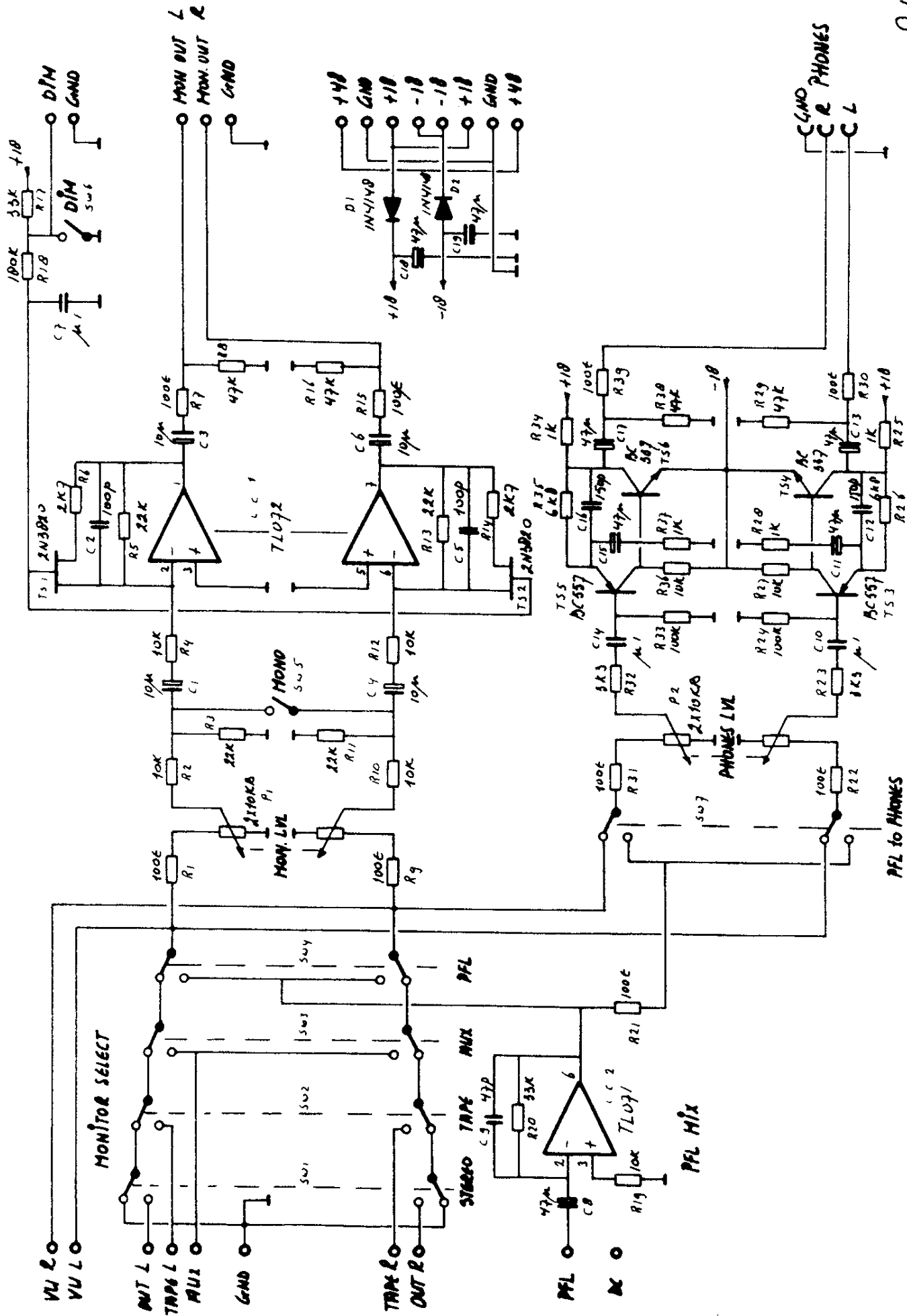

EELA AUDIO 18-06-81 FIVE

MONITOR MODULE S100 STEREO UNAMPLIFIED

817

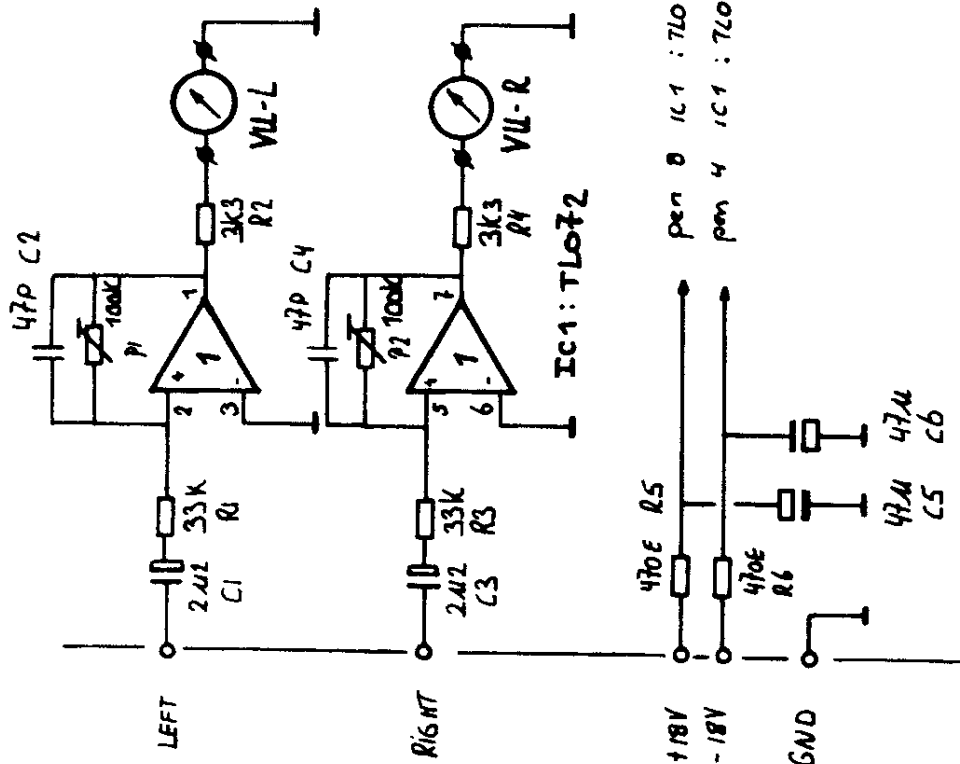

| | | | |
|---------------------------------------|-----------|----------|-------|
| PROJECT/OORDER | S100 | ORDER NR | 86734 |
| NAME | VU-METER. | | |
| DATE | 12-3-86 | NC | 4 |
| | | | |
| HONDSRUGLAAN 83a 5628 DB EINDHOVEN NL | | | |

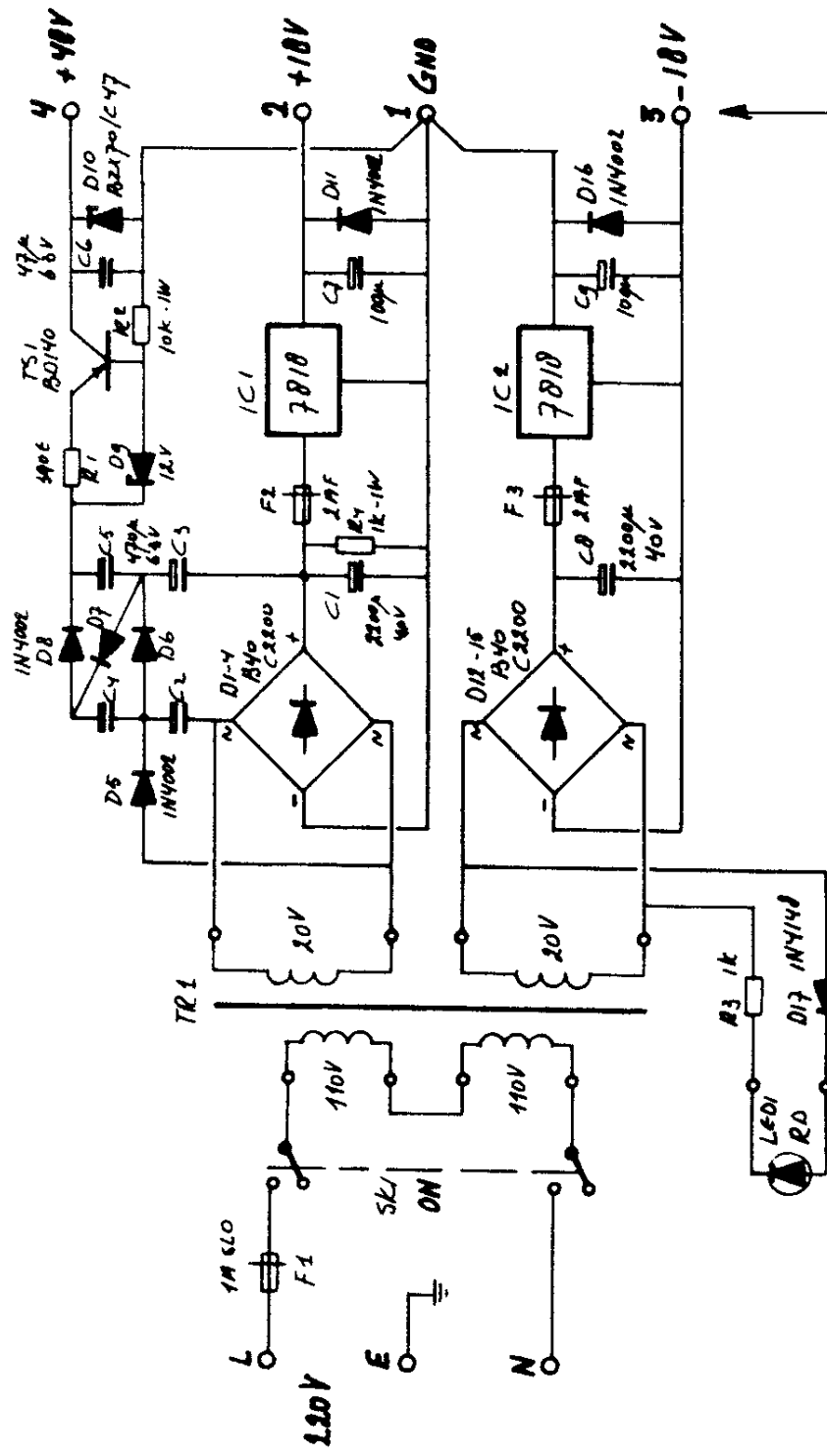

X12 4P (NC4 FC)

| | | | |
|---------------------------------------|--------------|----------|-----|
| PROJECT/ORDER | YOEDING S100 | ORDER NR | 1 |
| NAME | FYE | 83297 | 1 |
| DATE | 22-12-83 | | |
| | | | |
| HONDSRUGLAAN 83a 5628 DB EINDHOVEN NL | | | |
| | | | NC |
| | | | A 4 |

